

# PMI IMACS

**I**NTEGRATED **M**ACHINERY, **A**LARM and **C**ONTROL **S**YSTEM

*Omni Chief* Distributed Control and Monitoring Unit

UDC Universal Display and Control Panels

PCH Control Heads with Electric Shaft and Remote Display

Engine Control Room Console

MPC-D Marine Propulsion Control System

Digital Tachometers

Tank Level Monitor



***MV LeConte***

**71.6 m RO/RO Ferry**

**Alaska Marine Highway System**

**PRIME MOVER CONTROLS INC.**

### SIMPLIFIED CONTROL SYSTEM BLOCK DIAGRAM

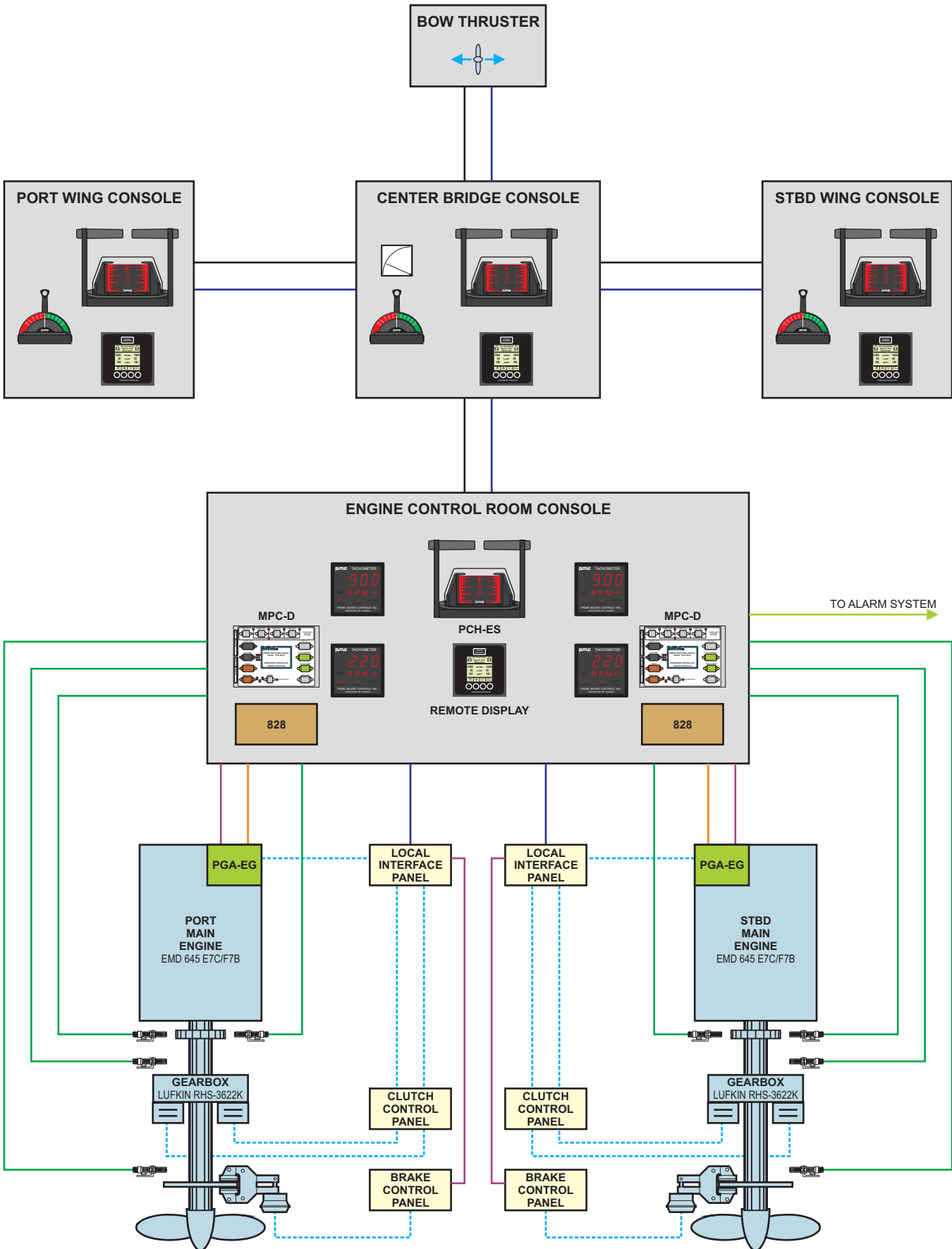

### SIMPLIFIED ALARM AND MONITORING SYSTEM BLOCK DIAGRAM

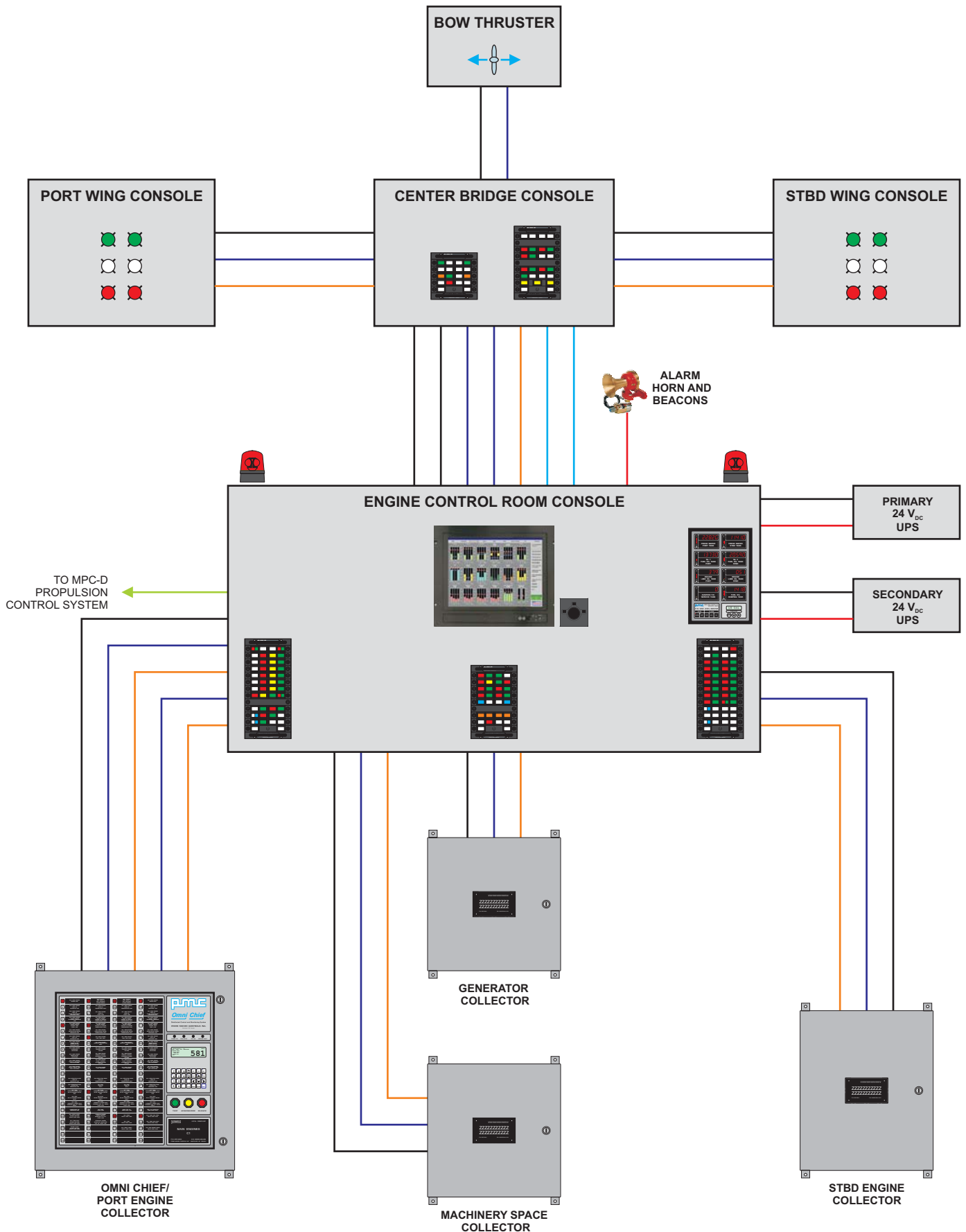



## PRIME MOVER CONTROLS INC.

3600 GILMORE WAY, BURNABY BC CANADA V5G 4R8

TEL 604 433-4644 FAX 604 433-5570 [www.pmc-controls.com](http://www.pmc-controls.com)